

Panasonic®

Operating Instructions

5.8 GHz Expandable Digital Cordless Camera

Model No. **KX-TGA573**

Indoor Use Only

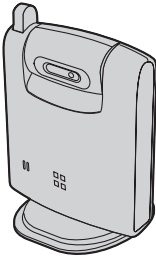

This cordless camera is an accessory unit for use with Panasonic base units KX-TG5761/KX-TG5766/KX-TG5767/KX-TG5771/KX-TG5776/KX-TG5777. You must register this cordless camera with your base unit before it can be used.

Camera monitoring requires a color display handset (KX-TGA571).

Please read these Operating Instructions before using the unit and save for future reference.

For assistance, visit our website:

<http://www.panasonic.com/phonehelp> for customers in the U.S.A. or Puerto Rico.

Table of Contents

Introduction

Introduction	3
Accessory information	4
Important safety instructions	5
For best performance	6

Preparation

Controls	7
Setting up the cordless camera	8
Symbols used in these operating instructions	11
Registering the cordless camera	12

Camera Monitoring

Camera monitoring using a handset . . .	13
---	----

Useful Information

Wall mounting	17
Troubleshooting	20
FCC and other information	22
Specifications	23
Customer services	24
Warranty	25

Index

Index	27
-----------------	----

Introduction

Thank you for purchasing the Panasonic 5.8 GHz expandable digital cordless camera.

We recommend keeping a record of the following information for future reference.

Serial No. (found on the bottom of the unit)	Date of purchase
Name and address of dealer	

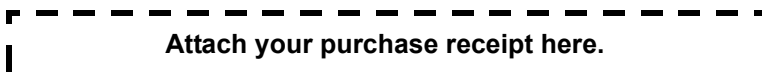

Feature highlight

Camera monitoring using the color display handset

Important:

- This unit is compatible only with the 5.8 GHz expandable digital cordless handset KX-TGA571 (color display type). For further information or to order the handset, visit <http://www.panasonic.com> or call phone number noted on page 4.
- In these operating instructions, the term “handset” is used to refer to the color display handset (KX-TGA571).

You can monitor the room where the cordless camera is located when:

- you access the cordless camera using the handset (page 13).
- the cordless camera pages the handset when it detects sound (page 14).
- the cordless camera user pages the handset using the call button (page 15).

Accessory information

Included accessories

No.	Accessory item	Order number	Quantity
①	AC adaptor for cordless camera	PQLV235Z	1
②	Wall-mounting adaptor for cordless camera	PQLP10267Z	1
③	Call button for cordless camera	PQLP10270Z	1

①

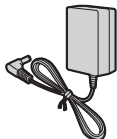

②

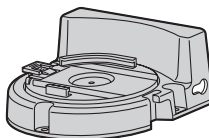

③

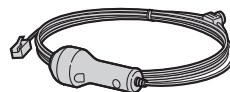

Sales and support information

- To order these accessories, call 1-800-332-5368.
- TTY users (hearing or speech impaired users) can call 1-866-605-1277.

Important safety instructions

When using the product, basic safety precautions should always be followed to reduce the risk of fire, electric shock, or personal injury.

1. Read and understand all instructions.
2. Keep these instructions.
3. Heed all warnings.
4. Follow all instructions.
5. After cleaning away the dust on the lens, wipe the lens with a cotton bud.
6. Do not install near any heat sources such as radiators, heat registers, stoves, or other devices (including amplifiers) that produce heat.
7. Protect the AC adaptor cord from being walked on or pinched particularly at plugs, receptacles, and the point where they exit from the unit.
8. Do not touch the unit or the AC adaptor during lightning storms.
9. Unplug the unit when unused for long periods of time.
10. Refer all servicing to qualified service personnel. Servicing is required when the unit has been damaged in any way, such as the AC adaptor cord or plug is damaged, the unit does not operate normally, or has been dropped.

SAVE THESE INSTRUCTIONS

CAUTION:

Installation

- Do not touch the plug with wet hands.
- The AC adaptor is used as the main disconnect device. Ensure that the AC outlet is installed near the product and is easily accessible.

WARNING:

- To prevent the risk of fire or electrical shock, do not expose the product to rain or any type of moisture.
- Unplug the product from power outlets if it emits smoke, an abnormal smell, or makes an unusual noise. These conditions can cause fire or electric shock. Confirm that smoke has stopped emitting and contact the Panasonic Call Center at 1-800-211-PANA (1-800-211-7262).

Medical

- Consult the manufacturer of any personal medical devices, such as pacemakers or hearing aids, to determine if they are adequately shielded from external RF (radio frequency) energy. (The product operates in the frequency range of 5.76 GHz to 5.84 GHz, and the power output is 200 mW (max.)) Do not use the product in health care facilities if any regulations posted in the area instruct you not to do so. Hospitals or health care facilities may be using equipment that could be sensitive to external RF energy.

For best performance

Avoiding noise

This unit communicates using radio waves.

For maximum distance and noise-free operation, we recommend placing the product away from electrical appliances.

Environment

- Keep the product away from electrical noise generating devices, such as fluorescent lamps and motors.
- The product should be kept free from excessive smoke, dust, high temperature, and vibration.
- The product should not be exposed to direct sunlight.
- Do not place heavy objects on top of the product.
- The product should be kept away from heat sources such as heaters, kitchen stoves, etc. It should not be placed in rooms where the temperature is less than 5 °C (41 °F) or greater than 40 °C (104 °F). Damp basements should also be avoided.
- Operating the product near 5.8 GHz electrical appliances may cause interference. Move away from the electrical appliances.

Routine care

- Wipe the outer surface of the product with a soft moist cloth. Do not use benzine, thinner, or any abrasive powder.

Conditions for using the cordless camera

- The cordless camera is intended for indoor use only. Prolonged exposure to direct sunlight or halogen light may damage the camera lens.
- Use the cordless camera in a bright place such as under daylight or a well-lit room.
- Do not use the cordless camera in the following places:
 - near incandescent lamps.
 - near any electrical appliance that emits a strong radio signal.
 - where the subject of the picture is against a light source or in front of a mirror.
 - in places where temperature varies greatly, such as near an air conditioner or heater.
 - any place exposed to oil or steam such as a kitchen.
 - where an object such as glass can cause temperature change due to reflection.
- When using the cordless camera, please take into consideration the rights of others with regard to privacy.

Controls

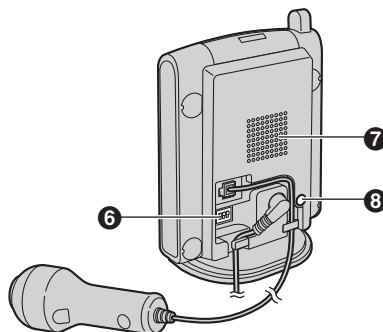
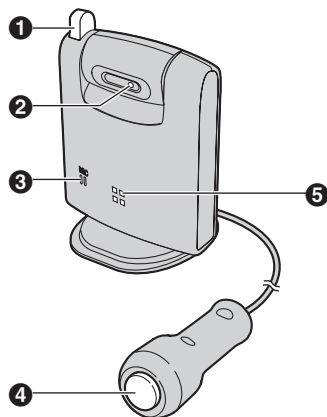

- | | |
|---------------------------|--------------------------|
| 1 Antenna | 5 Indicator |
| 2 Camera lens | 6 DIP switches |
| 3 MIC (Microphone) | 7 Speaker |
| 4 [Call button] | 8 PROG. (Program) |

Understanding the cordless camera indicator

The cordless camera indicator shows the status as follows.

Status	Description
Red (flashing rapidly)	<ul style="list-style-type: none"> • The cordless camera is not registered. Register the cordless camera (page 12). • The cordless camera is out of range. Locate the cordless camera near the base unit.
Yellow-green	<ul style="list-style-type: none"> • The cordless camera is registered and in standby mode.
Yellow-green (flashing)	<ul style="list-style-type: none"> • The camera sensor is responding and the cordless camera is paging the handset. • The cordless camera is connected and sending live images to the handset.

Setting up the cordless camera

Connecting the AC adaptor and the call button

Connect the AC adaptor cord by pressing the plug firmly **(1)**. Connect the call button cord until it clicks into the unit **(2)**.

- Use only the included Panasonic AC adaptor PQLV235.

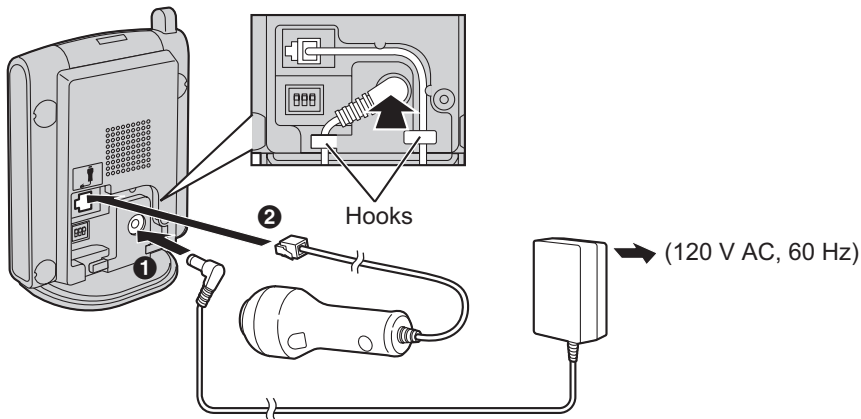

Note:

- When the AC adaptor is connected, the indicator lights in red then starts flashing.
- The AC adaptor must remain connected at all times. (It is normal for the adaptor to feel warm during use.)
- The AC adaptor should be connected to a vertically oriented or floor-mounted AC outlet. Do not connect the AC adaptor to a ceiling-mounted AC outlet, as the weight of the adaptor may cause it to become disconnected.

Adjusting the cordless camera lens angle

Aim the camera lens by pushing the tab (❶) and rotating the lens forward or backward.

- Using the handset, confirm that the area you want to monitor from the cordless camera is displayed (page 13).

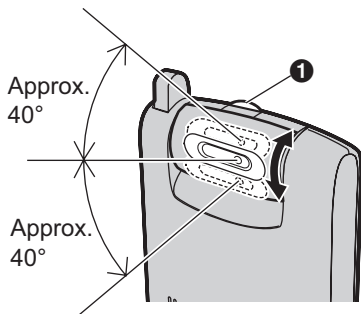

Note:

- Do not touch the camera lens (page 7).

Setting the DIP switches

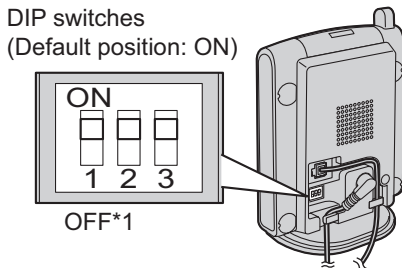

You can set the following functions by using the DIP switch 1 to 3.

Slide each switch with a pointed object such as a pen as necessary.

After repositioning the DIP switches to your preferred settings, unplug the AC adaptor then reconnect it. The cordless camera is reset to these settings.

DIP switch	Function	ON (default)	OFF*1
1	Image orientation	Standard	Upside down
2	Image quality	Standard quality mode	Enhanced motion mode
3	Speaker volume	Standard	Low

*1 Slide the switch to down.

Displaying the image upside down (DIP switch 1)

To turn the camera image upside down, set to OFF. This feature is useful when you mount the cordless camera upside down (page 18).

Selecting image quality (standard quality mode/enhanced motion mode) (DIP switch 2)

If you want enhanced motion, set to OFF (Enhanced motion mode). The image clarity decreases.

If you want to improve the image clarity, leave at ON (Standard quality mode). The motion becomes less enhanced.

Selecting the cordless camera speaker volume (DIP switch 3)

If you want to lower the speaker volume, set to OFF (LOW).

Symbols used in these operating instructions

Symbol	Meaning
<p>[]: button name/soft key name</p> <p>Example: Unit keys: [INTERCOM], [OFF] Soft keys: [CALL]</p>	<p>The words in the brackets indicate button names/soft key names on the handset and base unit.</p>
<p>Example:</p> <p>1 [INTERCOM]</p> <p>2 Select the desired cordless camera. → [CALL]</p> <p>3 [MUTE]</p> <p>4 [OFF]</p>	<p>1 Press [INTERCOM].</p> <p>2 Push the joystick up or down to select the desired cordless camera, then press [CALL].</p> <p>3 Press [MUTE].</p> <p>4 Press [OFF].</p>
[▲] [▼]	Push the joystick up or down.

Registering the cordless camera

Register the cordless camera to a KX-TG5761/KX-TG5766/KX-TG5767/KX-TG5771/KX-TG5776/KX-TG5777 base unit.

1 Base unit:

Press and hold **[INTERCOM]** until the IN USE indicator flashes.

- After the IN USE indicator starts flashing, the rest of the procedure must be completed within 90 seconds.

2 Cordless camera:

Press PROG. (program) on the back side of the cordless camera with a pointed object such as a pen until a beep sounds.

- When registration is completed successfully, the cordless camera beeps and the indicator stops flashing red but remains lit in yellow-green (page 7).

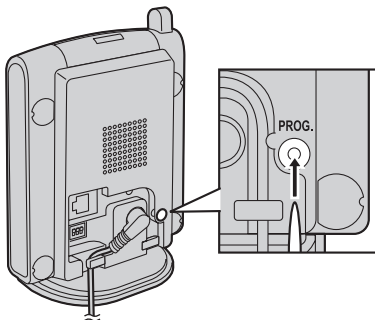

Deregistering the cordless camera

The base unit can cancel the registration of a registered cordless camera.

Important:

- Before deregistering, confirm the cordless camera's extension number from the handset (color display models only: KX-TGA571). Press **[INTERCOM]** on the handset to display its extension.

Base unit

- 1 Press and hold **[INTERCOM]** until the IN USE indicator flashes.
- 2 Press and hold the cordless camera's extension number (**[1]** – **[8]**) until a beep sounds.

Note:

- The indicator color on the camera remains the same.

Camera monitoring using a handset

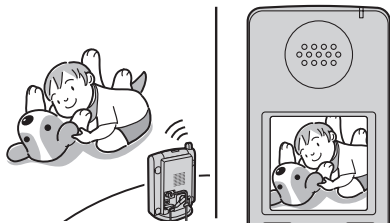

With a color display handset (KX-TGA571), you can monitor the image and sound of the room where the cordless camera is located. The monitored camera does not ring, allowing you to easily monitor a baby's room, for example, from different areas of the house.

Important:

- Before you start monitoring, confirm that the camera lens of the cordless camera has been adjusted to the correct angle.
- Only 1 person can access the cordless camera at a time.
- A refreshed image taken by the cordless camera is displayed every few seconds. The displayed image is not a moving picture. Selecting enhanced motion mode shortens the interval (page 10).
- While monitoring a cordless camera, other users cannot make an intercom call or transfer a call.
- The monitoring connection is automatically canceled after 10 minutes.
- While monitoring you cannot place the handset on the base unit or charger. The monitoring connection will be canceled.

- The cordless camera may not page handsets in the following conditions:
 - when other users are on an intercom or conference call.
 - when electrical interference is emitted from electrical devices.
 - while you are on a call with the handset. (In this case you will hear 2 tones and  will flash on the handset.)

Monitoring the cordless camera from a handset

Handset

- 1 [INTERCOM]**
- 2** Select the desired cordless camera.
→ **[CALL]**
- 3** Speak to the cordless camera user if necessary.
OR
To mute your sound output, press **[MUTE]** if necessary.
- 4** When you finish monitoring, press **[OFF]** or place the handset on the base unit or charger.

Adjusting receiver/speaker volume

Push **[▲]** or **[▼]** while monitoring.

Talking to the paged party using the cordless camera

When the cordless camera is paged from a handset, the cordless camera does not ring and the speakerphone is turned on. You can talk to the handset user. Speak clearly into the MIC.



Handset display item for camera monitoring

Displayed item	Meaning
Example: 	The handset is connected to the cordless camera. When flashing: The cordless camera is paging the handset. (It detects sound or its [Call button] is pressed.)

Paging the handsets from the cordless camera

The cordless camera can page color display handsets (KX-TGA571) when it detects sound or by pressing its **[Call button]**. Then the answering handset user can monitor live images from the cordless camera.

Important:

- Only registered color display handsets (KX-TGA571) can be paged from the cordless camera. The base unit and monochrome display handsets (KX-TGA570) cannot be paged.
- If a handset is paged by the cordless camera during a call, 2 tones sound and  flashes on the handset. To monitor the cordless camera from the handset, press **[OFF]**, then press .
- Auto intercom feature cannot be used when paged by a cordless camera.

Paging using the cordless camera audio sensor

Important:

- You can adjust the audio detection sensitivity (page 16).

1 Cordless camera:

The cordless camera detects sound.

- The cordless camera produces a camera tone and pages the handsets for 1 minute.

2 Handset:

Press  to answer the page.

- You can monitor the room where the cordless camera is located.

3 Handset:

To mute your sound output, press **[MUTE]** if necessary.

4 Handset:

When you finish monitoring, press **[OFF]** or place the handset on the base unit or charger.

Paging using the cordless camera call button

1 Cordless camera:

Press **[Call button]**.

- The cordless camera produces a camera tone and pages the handsets for 1 minute.

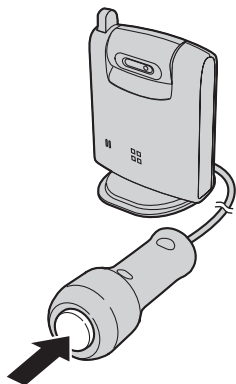

2 Handset:

Press **[Call]** to answer the page.

- You can monitor the room where the cordless camera is located.

3 Cordless camera:

When the handset user answers, speak clearly into the MIC.

4 Handset:

When you finish monitoring, press **[OFF]** or place the handset on the base unit or charger.

Useful settings while camera monitoring

With a color display handset (KX-TGA571), you can set the camera settings while monitoring.

Important:

- Each time you press **[OPTION]**, the right soft key switches between **[BRIGHT]**, **[ZOOM]**, and **[SENSOR]**.

Adjusting the display brightness

There are 6 levels.

- 1 Start monitoring (page 13).
- 2 Press **[OPTION]** repeatedly until **[BRIGHT]** is displayed.
- 3 Press **[BRIGHT]** repeatedly to adjust the brightness.

Note:

- When you finish monitoring, the setting is reset to the default.

Selecting image zoom

- 1 Start monitoring (page 13).
- 2 Press **[OPTION]** repeatedly until **[ZOOM]** is displayed.
- 3 Press **[ZOOM]** to zoom in on the image.
 - To return to the original view, press **[ZOOM]** again.

Setting the audio detection sensitivity

The cordless camera features a sensor that detects human voices such as a baby cry. Sounds other than human voices may be difficult to detect. To use this feature, confirm that the cordless camera is located in a place where it can easily detect voices. Once the sensor has detected sound, the cordless camera pages the handset.

To use the audio detection feature of the cordless camera, turn the audio detection sensitivity to on.

There are 3 levels. The default setting is "off".

- 1** Start monitoring (page 13).
- 2** Press **[OPTION]** repeatedly until **[SENSOR]** is displayed.
- 3** **[SENSOR]**
- 4** To turn the feature on, push **[▲]**.
Push **[▲]** or **[▼]** to select the desired sensitivity.
 - To turn this feature off, push **[▼]** repeatedly.

5 **[SAVE]**

Note:

- When you turn this feature off, the cordless camera cannot detect sound (page 14).
- To set the appropriate level, test the sensor of the camera from the handset beforehand.

Wall mounting

The cordless camera can be mounted by the standard mounting or upside down mounting.

CAUTION:

- Mount the cordless camera on the stable location where the unit can be adequately supported when installing.
- The AC adaptor should be connected to a vertically oriented or floor-mounted AC outlet. Do not connect the AC adaptor to a ceiling-mounted AC outlet, as the weight of the adaptor may cause it to become disconnected.
- **Do not mount the cordless camera on a soft material. It may fall down, break or cause injury.**
- Do not mount the cordless camera on the following places: plaster board, ALC (autoclaved lightweight cellular concrete), concrete block, plywood less than 25 mm (1 inch) thick, and etc.
- Do not pull the call button wire after you mount the cordless camera on the wall.
- After mounting the cordless camera on the wall, speak loudly and clearly into the MIC when talking with the handset user.

Connecting the wall-mounting adaptor

- ❶ Slide the cordless camera into the wall-mounting adaptor in the direction of the arrow until it clicks into the place.
- ❷ Tuck the call button wire into the hole on the side of the wall-mounting adaptor by plugging the small wire fixture into the hole.
- ❸ Turning it slightly and sliding it in place.
- ❹ Fasten the call button wire to the hook of the wall-mounting adaptor.

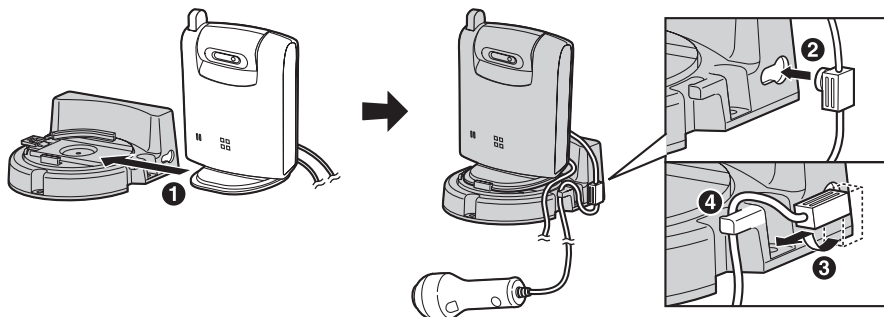

Mounting the cordless camera on the wall

Standard mounting

- 1 Drive the screws (not included) into the wall at a recommended height of 1.8 m (5.9 feet) or below using the wall mount template as a guide (page 19).

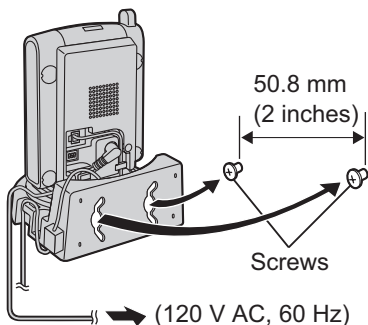

- 2 Mount the cordless camera (1), then slide it down (2) and to the right (3) until it is secure.

- To aim the camera lens, see page 9.

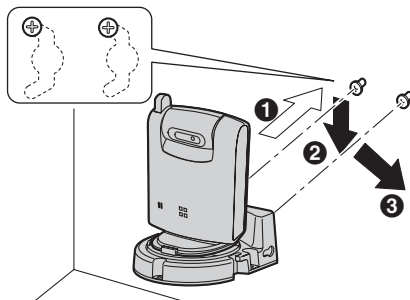

Upside down mounting

- The image may be seen upside down when mounting upside down. To compensate for this, change the cordless camera setting to display images upside down (page 10).

- 1 Drive the screws (not included) into the wall at a recommended height of 1.8 m (5.9 feet) or below using the wall mount template as a guide (page 19).

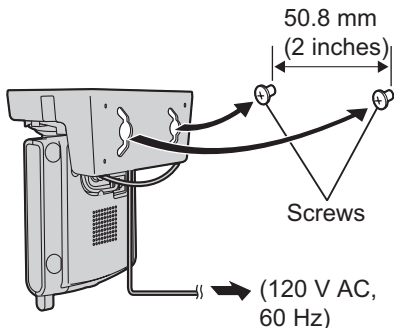

- 2 Mount the cordless camera (1), then slide it down (2) and to the left (3) until it is secure.

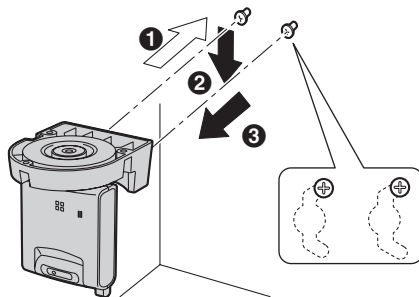

About the screws for wall mounting

- Use the recommended screw size below.
- Drive the mounting screws leaving enough length from the wall to hook the cordless camera.

Max. 9.3 mm
($23/64$ inch)

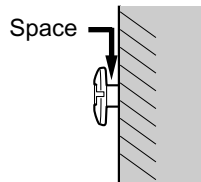

Max. 4.5 mm
($11/64$ inch)

**Removing the wall-mounting adaptor**

Press and hold the hold button (❶) on the left side of the wall-mounting plate. Slide the cordless camera to the right (❷).

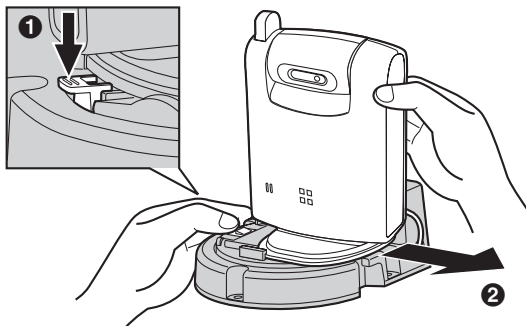
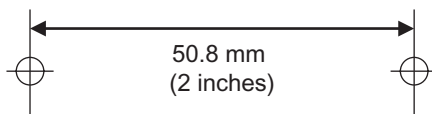
**Wall mount template for the cordless camera**

Troubleshooting

Problem	Cause & solution
The cordless camera does not work.	<ul style="list-style-type: none">● Check the connections (page 8).● The cordless camera is not registered to the base unit. Register the cordless camera to the base unit (page 12).
The cordless camera's indicator is flashing red.	<ul style="list-style-type: none">● The cordless camera is not registered to the base unit. Register the cordless camera to the base unit (page 12).● The cordless camera is out of range. Locate the cordless camera near the base unit.
The image is faint.	<ul style="list-style-type: none">● The camera lens is dirty. Clean it with a soft dry cloth.● Do not touch the lens directly. Fingerprint may cause an unclear image.
The image sent from the cordless camera is poor on the handset display.	<ul style="list-style-type: none">● Adjust the display brightness setting (page 15).● Select standard quality mode instead of enhanced motion mode (page 10).● The place where the cordless camera is located is dark. Improve lighting.
The image sent from the cordless camera is dark and difficult to see on the handset display.	<ul style="list-style-type: none">● Adjust the display brightness setting (page 15).● There is a strong sunlight or a backlight in the place where the cordless camera is located. Try shading the camera's location.
I cannot connect to the cordless camera, the image distorts, or the image is slow.	<ul style="list-style-type: none">● The cordless camera has lost communications with the base unit. Move the cordless camera closer to the base unit, and try again.● There is an obstacle such as concrete wall. Move the cordless camera to the place without an obstacle.● A microwave appliance is in use. Move the cordless camera closer to the base unit or use the cordless camera away from that appliance, and try again.
The camera sensor does not respond.	<ul style="list-style-type: none">● If you set the audio detection sensitivity to off, the camera sensor does not respond. Turn this feature on (page 16).● While a handset is monitoring the cordless camera, the cordless camera stops detecting sound.

Problem	Cause & solution
I pressed 【Call button】 but the cordless camera does not page the handsets.	<ul style="list-style-type: none">• While the image of the cordless camera is being monitored by a handset, 【Call button】 will not have response.
The handset speaker and/or the cordless camera emit a howling noise while monitoring.	<ul style="list-style-type: none">• Move the handset away from the cordless camera.
When using the handset speakerphone to have an intercom call with the cordless camera, sound cuts in and out and you have difficulty hearing the other party.	<ul style="list-style-type: none">• Lower the speaker volume by pushing 【v】.

FCC and other information

This device complies with Part 15 of the FCC Rules. Operation is subject to the following two conditions:

(1) This device may not cause harmful interference, and (2) this device must accept any interference received, including interference that may cause undesired operation.

CAUTION:

Any changes or modifications not expressly approved by the party responsible for compliance could void the user's authority to operate this device.

NOTE:

This equipment has been tested and found to comply with the limits for a Class B digital device, pursuant to Part 15 of the FCC Rules. These limits are designed to provide reasonable protection against harmful interference in a residential installation. This equipment generates, uses, and can radiate radio frequency energy and, if not installed and used in accordance with the instructions, may cause harmful interference to radio communications. However, there is no guarantee that interference will not occur in a particular installation. If this equipment does cause harmful interference to radio or television reception, which can be determined by turning the equipment off and on, the user is encouraged to try to correct the interference by one or more of the following measures:

- Reorient or relocate the receiving antenna.
- Increase the separation between the equipment and receiver.

- Connect the equipment into an outlet on a circuit different from that to which the receiver is connected.
- Consult the dealer or an experienced radio/TV technician for help.

FCC RF Exposure Warning:

The product complies with FCC radiation exposure limits set forth for an uncontrolled environment. To comply with FCC RF exposure requirements, the product must be installed and operated with its antenna located 20 cm (8 inches) or more away from all person's body (excluding extremities of hands, wrist and feet). The product must not be collocated or operated in conjunction with any other antenna or transmitter.

Notice

- This product is designed for use in the United States of America. Sale or use of this product in other countries may violate local laws.
- Cet appareil est conçu pour être utilisé aux États-Unis d'Amérique. La vente ou l'emploi de cet appareil dans certains autres pays peut constituer une infraction à la législation locale.
- Este producto está diseñado para usarse en los Estados Unidos de América. La venta o el empleo de este producto en ciertos países puede constituir violación de la legislación local.
- この製品は、日本国外での使用を目的として設計されており、日本国内での使用は法律違反となります。従って、当社では日本国内においては原則として修理などのサービスは致しかねます。

Specifications

Operating environment	5 °C – 40 °C (41 °F – 104 °F)
Frequency	5.76 GHz – 5.84 GHz
Dimensions	Approx. height 124 mm x width 86 mm x depth 68 mm (4 ⁷ / ₈ inches x 3 ³ / ₈ inches x 2 ¹¹ / ₁₆ inches)
Mass (Weight)	Approx. 150 g (0.33 lb.)
Power consumption	Standby: Approx. 1.5 W Maximum: Approx. 2.8 W
Power output	200 mW (max.)
Power supply	AC adaptor (120 V AC, 60 Hz)
Number of pixels	11,776 pixels
Illuminance	10 lux (min.)
Focus	Fixed 0.25 m (9 ²⁷ / ₃₂ inches) – Infinity
Photograph angle	Vertical angle: Approx. 35° Horizontal angle: Approx. 45°

Note:

- Design and specifications are subject to change without notice.
- The illustrations in these instructions may vary slightly from the actual product.

Customer services

Customer Services Directory

Obtain Product Information and Operating Assistance; locate your nearest Dealer or Servicenter; purchase Parts and Accessories; or make Customer Service and Literature requests by visiting our Web Site at:

<http://www.panasonic.com/consumersupport>

or, contact us via the web at:

<http://www.panasonic.com/contactinfo>

You may also contact us directly at: 1-800-211-PANA (1-800-211-7262), Monday-Friday 9 am-9 pm; Saturday-Sunday 10 am-7 pm, EST.

TTY users (hearing or speech impaired users) can call 1-877-833-8855.

Accessory Purchases

Purchase Parts, Accessories and Instruction Books online for all Panasonic Products by visiting our Web Site at:

<http://www.pasc.panasonic.com>

or, send your request by E-mail to:

npcparts@us.panasonic.com

You may also contact us directly at:

1-800-332-5368 (Phone) 1-800-237-9080 (Fax Only)

(Monday - Friday 9 am to 9 pm, EST.)

Panasonic Services Company

20421 84th Avenue South, Kent, WA 98032

(We Accept Visa, MasterCard, Discover Card, American Express, and Personal Checks)

TTY users (hearing or speech impaired users) can call 1-866-605-1277.

Service in Puerto Rico

Panasonic Puerto Rico, Inc.

San Gabriel Industrial Park, Ave. 65 de Infantería, Km. 9.5,

Carolina, Puerto Rico 00985

Phone (787)750-4300, Fax (787)768-2910

Warranty

PANASONIC CONSUMER
ELECTRONICS COMPANY, DIVISION
OF PANASONIC CORPORATION OF
NORTH AMERICA

One Panasonic Way,
Secaucus, New Jersey 07094

PANASONIC PUERTO RICO, INC.
San Gabriel Industrial Park,
Ave. 65 de Infantería, Km. 9.5,
Carolina, Puerto Rico 00985

Panasonic Telephone Products Limited Warranty

Limited Warranty Coverage

If your product does not work properly because of a defect in materials or workmanship, Panasonic Consumer Electronics Company or Panasonic Puerto Rico, Inc. (collectively referred to as "the warrantor") will, for the length of the period indicated on the chart below, which starts with the date of original purchase ("Limited Warranty period"), at its option either (a) repair your product with new or refurbished parts, or (b) replace it with a new or a refurbished product. The decision to repair or replace will be made by the warrantor.

Parts

One (1) Year

Labor

One (1) Year

During the "Labor" Limited Warranty period there will be no charge for labor. During the "Parts" Limited Warranty period, there will be no charge for parts. You must mail-in your product prepaid during the Limited Warranty period. This Limited Warranty excludes both parts and labor for batteries, antennas, and cosmetic parts (cabinet). This Limited Warranty only applies to products purchased and serviced in the United States or Puerto Rico. This Limited Warranty is extended only to the original purchaser and only covers products purchased as new.

Mail-In Service

For assistance in the continental U.S.A. in obtaining repairs please ship the product prepaid to:

Panasonic Services Company Customer Servicenter

4900 George McVay Drive Suite B Door #12 McAllen, TX 78503

For assistance in Puerto Rico call Panasonic Puerto Rico, Inc. (787)-750-4300 or fax (787)-768-2910.

For Limited Warranty service for headsets if a headset is included with this product please call Panasonic Call Center at 1-800-211-PANA (1-800-211-7262).

When shipping the unit carefully pack, include all accessories, and send it prepaid, adequately insured and preferably in the original carton. Include a letter detailing the complaint and provide a day time phone number where you can be reached.

IF REPAIR IS NEEDED DURING THE LIMITED WARRANTY PERIOD THE PURCHASER WILL BE REQUIRED TO FURNISH A SALES RECEIPT/PROOF OF PURCHASE INDICATING DATE OF PURCHASE, AMOUNT PAID AND PLACE OF PURCHASE. CUSTOMER WILL BE CHARGED FOR THE REPAIR OF ANY UNIT RECEIVED WITHOUT SUCH PROOF OF PURCHASE.

Limited Warranty Limits And Exclusions

This Limited Warranty ONLY COVERS failures due to defects in materials or workmanship, and DOES NOT COVER normal wear and tear or cosmetic damage. The Limited Warranty ALSO DOES NOT COVER damages which occurred in shipment, or failures which are caused by products not supplied by the warrantor, or failures which result from accidents, misuse, abuse, neglect, bug infestation, mishandling, misapplication, alteration, faulty installation, set-up adjustments, misadjustment of consumer controls, improper maintenance, power line surge, lightning damage, modification, introduction of sand, humidity or liquids, commercial use such as hotel, office, restaurant, or other business or rental use of the product, or service by anyone other than a Factory Servicenter or other Authorized Servicer, or damage that is attributable to acts of God.

THERE ARE NO EXPRESS WARRANTIES EXCEPT AS LISTED UNDER "LIMITED WARRANTY COVERAGE". THE WARRANTOR IS NOT LIABLE FOR INCIDENTAL OR CONSEQUENTIAL DAMAGES RESULTING FROM THE USE OF THIS PRODUCT, OR ARISING OUT OF ANY BREACH OF THIS LIMITED WARRANTY. (As examples, this excludes damages for lost time, lost calls or messages, cost of having someone remove or re-install an installed unit if applicable, travel to and from the servicer. The items listed are not exclusive, but are for illustration only.) **ALL EXPRESS AND IMPLIED WARRANTIES, INCLUDING THE WARRANTY OF MERCHANTABILITY, ARE LIMITED TO THE PERIOD OF THE LIMITED WARRANTY.**

Some states do not allow the exclusion or limitation of incidental or consequential damages, or limitations on how long an implied warranty lasts, so the exclusions may not apply to you.

This Limited Warranty gives you specific legal rights and you may also have other rights which vary from state to state. If a problem with this product develops during or after the Limited Warranty period, you may contact your dealer or Servicenter. If the problem is not handled to your satisfaction, then write to the warrantor's Consumer Affairs Department at the addresses listed for the warrantor.

PARTS AND SERVICE, WHICH ARE NOT COVERED BY THIS LIMITED WARRANTY, ARE YOUR RESPONSIBILITY.

Index

- A** Answering the page: 15
- Audio detection sensitivity: 16
- C** Call button: 8, 15
- Camera angle: 9
- Camera indicator: 7
- Camera monitoring: 13
- Camera tone: 14
- Connection
 - AC adaptor: 8
 - Wall-mounting adaptor: 17
- Cordless Camera Settings
 - Audio detection sensitivity: 16
 - Brightness: 15
 - Image orientation (Upside down): 10
 - Image quality: 10
 - Image zoom: 15
 - Speaker volume: 10
- D** Deregistration: 12
- DIP switches: 10
- I** Image orientation: 10
- Image quality: 10
- P** Paging handsets: 15
- R** Registering the cordless camera: 12
- S** Speaker volume: 10
- Specifications: 23
- T** Troubleshooting: 20
- TTY: 4, 24
- W** Wall mounting: 17
- Wall-mounting adaptor: 17
- Warranty: 25

If you need assistance with setup or operation

- 1** Visit our website: <http://www.panasonic.com/phonehelp>
- 2** Contact us via the web at: <http://www.panasonic.com/contactinfo>
- 3** Call us at: 1-800-211-PANA (1-800-211-7262)
TTY users (hearing or speech impaired users) can call 1-877-833-8855.

When you ship the product

- Carefully pack your unit, preferably in the original carton.
- Attach a letter, detailing the symptom, to the outside of the carton.
- Send the unit to Panasonic Services Company Customer Servicer, prepaid and adequately insured.
- Do not send your unit to Panasonic Consumer Electronics Company listed below or to executive or regional sales offices. These locations do not repair consumer products.

**Panasonic Consumer Electronics Company,
Division of Panasonic Corporation of North America**
One Panasonic Way, Secaucus, New Jersey 07094

Panasonic Puerto Rico, Inc.
San Gabriel Industrial Park, Ave. 65 de Infantería, Km. 9.5,
Carolina, Puerto Rico 00985

Copyright:

This material is copyrighted by Panasonic Communications Co., Ltd., and may be reproduced for internal use only. All other reproduction, in whole or in part, is prohibited without the written consent of Panasonic Communications Co., Ltd.
© 2006 Panasonic Communications Co., Ltd. All Rights Reserved.



TGA573

PQQX15085YA DM0306SN2046